

## Ultra-thin Vertical Exposed Fan Coil Unit ( DC Motor )



## Features

### 1 High Efficiency & Energy Saving

- ▶ Compared with the traditional heating radiators, the ultra-thin fan coil unit can save more than 30% energy consumption.
- ▶ Compared with the traditional AC motor fan coil, the ultra-thin fan coil unit equipped with DC motor can save up to 50% energy consumption.

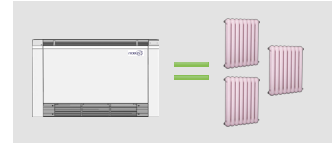

The capacity of 1 ultra-thin fan coil is equal to that of 3 common radiators.

### 2 Easy Installation

- ▶ The ultra-thin fan coil unit is flexible to be installed wherever you want because of its varied installation ways. Besides the ceiling installation, users can choose floor standing or wall mounted installation as well.

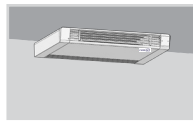

Ceiling Mounted

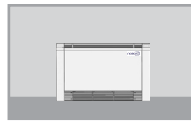

Floor Standing

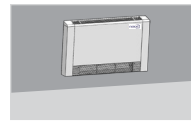

Wall Mounted

### 3 More Models More Choices

- ▶ We provide totally five different models in different casings. Users can pick one which best meets their requirement for heating/cooling.

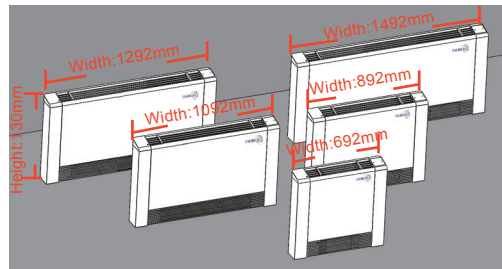

### 4 Creative and Detail-oriented Design

- ▶ Copper tube/aluminum fin coil with hydrophilic coating heat exchanger ensures the unit's higher efficiency and longer service life.
- ▶ Superior quality cross-flow fan brings the unit big air volume and low noise.
- ▶ The brushless fan motor makes the unit be with lower noise and higher speed in operation.



## Features

### 5 More Comfortable

- ▶ The ultra-thin fan coil unit adopts electronic commutation motor to replace the carbon brush motor to avoid electromagnetic interference and electromagnetic noise generated by the mechanical commutation. Its quiet operation and varied speed adjustment help create a comfortable indoor environment with a swift indoor temperature reponse and comfortable air flow.
- ▶ The traditional AC fan coil unit has a plus or minus 2°C indoor temperature deviation, which easily causes sudden hot or cold, while the ultra-thin fan coil unit achieves a plus or minus 0.5°C indoor temperature accuracy via motor varied speed regulation fan to create a more comfortable environment.

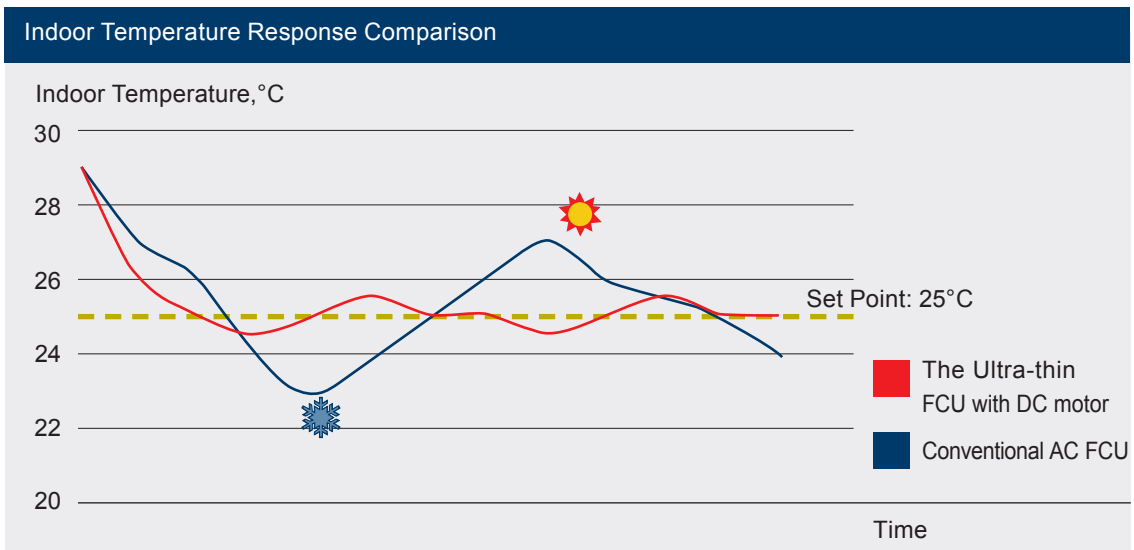

- ▶ The ultra-thin fan coil unit features stable running and slight vibration, greatly reducing vibration and noise caused by on/off switch.
- ▶ The ultra-thin fan coil unit can realize minimum RPM running via speed pre-adjustment.
- ▶ The ultra-thin fan coil unit has a proper diameter plastic fan and a low noise fan motor.
- ▶ Every unit is strictly tested for dynamic balancing before delivery, in order to ensure minimum noise level upon a satisfied air flow and external pressure basis.

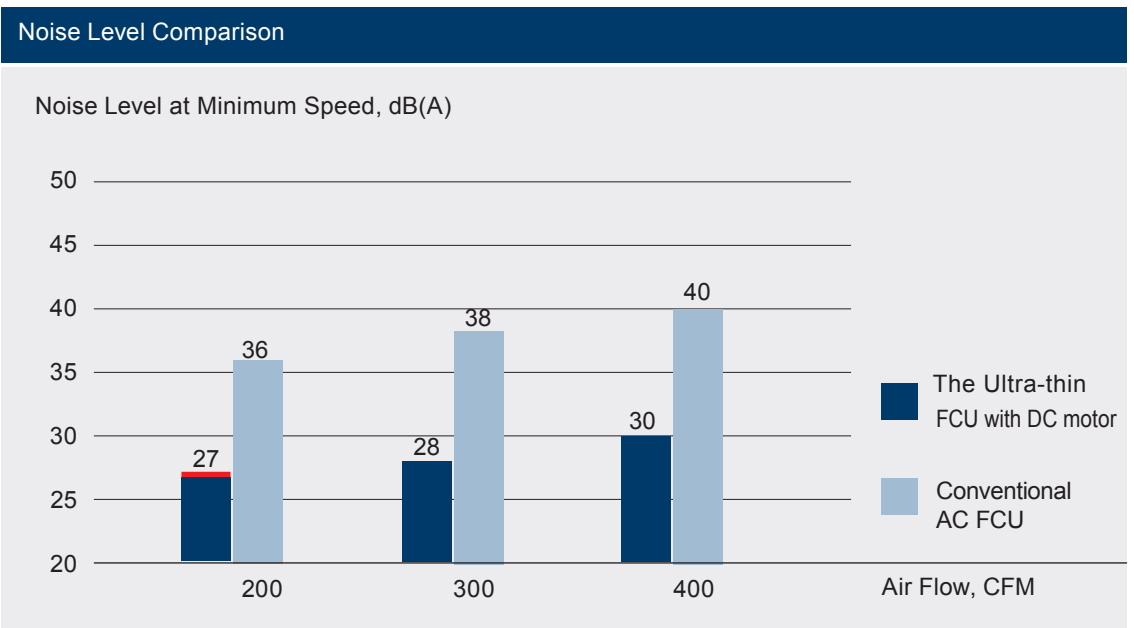

## Features

### 6 More Compact

- ▶ The ultra-thin fan coil unit features aesthetical outline and compact dimensions. The fuselage width is only 130 mm.
- ▶ The ultra-thin fan coil unit enjoys the most compact size compared with world class competitors.



### 7 More Reliable

- ▶ High quality and long life electronic commutation module is used to reduce traditional AC motor components wearing out during operation.
- ▶ The ultra-thin motor is equipped with high precision high quality permanent lubricated closed ball bearing, which is with low noise and long service life.
- ▶ The motor shaft is processed with conditioning chrome plating treatment, durable and reliable.
- ▶ Highly efficient heat exchanger is made of high quality hydrophilic aluminium fin. Precision machinery tube expansion ensures a high thermal efficiency on the copper tube.



## Features

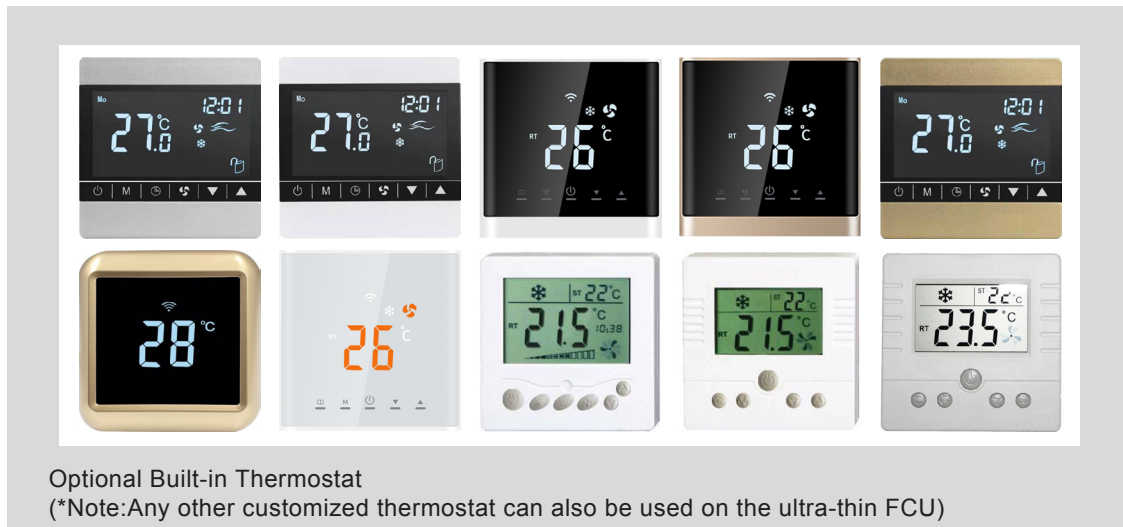

## 8 SMART Control

- ▶ We provide different types of controller options. Users can choose the controller with control buttons which is the easiest way for operation. Also users can select the advanced one with touch screen or directly use the remote controller to control the unit.
- ▶ The ultra-thin fan coil unit can also be controlled by wall thermostat, which is another convenient way for controlling.
- ▶ Moreover, RS485 communication is now available for users. Centralized control can be realized for the ultra-thin fan coil unit based on modbus protocol.

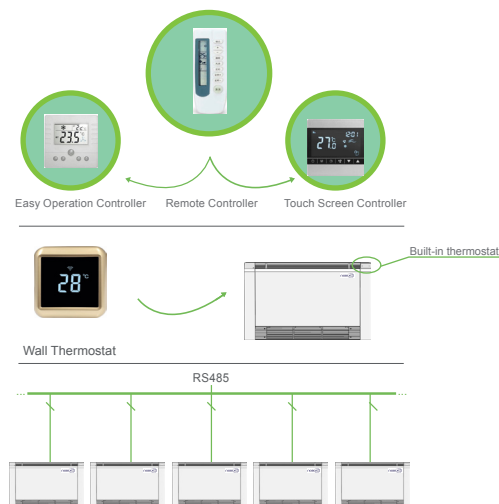

# Specifications

| Model                      |                   | FC-020VED     | FC-032VED   | FC-046VED    | FC-058VED    | FC-065VED    |
|----------------------------|-------------------|---------------|-------------|--------------|--------------|--------------|
| Air Flow Max.              | m <sup>3</sup> /h | 200           | 320         | 460          | 580          | 650          |
| Air Flow Min.              | m <sup>3</sup> /h | 80            | 120         | 180          | 220          | 260          |
| Cooling Capacity           | W                 | 1050          | 1980        | 2890         | 3620         | 4130         |
| Cooling Capacity           | BTU/h             | 3582          | 6755        | 9860         | 12351        | 14091        |
| Heating Capacity*          | W                 | 1500          | 2850        | 4200         | 5250         | 6000         |
| Heating Capacity*          | BTU/h             | 5118          | 9724        | 14330        | 17912        | 20471        |
| Heating Capacity**         | W                 | 2600          | 3985        | 5820         | 7250         | 9480         |
| Heating Capacity**         | BTU/h             | 8871          | 13596       | 19857        | 24736        | 32344        |
| Noise Level Max.           | dB(A)             | 30            | 32          | 36           | 38           | 40           |
| Noise Level Min.           | dB(A)             | 24            | 27          | 28           | 28           | 30           |
| Power Supply               | /                 | 220V/50Hz/1Ph |             |              |              |              |
| Power Input                | W                 | 18            | 24          | 35           | 40           | 45           |
| Water Flow                 | m <sup>3</sup> /h | 0.17          | 0.33        | 0.49         | 0.6          | 0.64         |
| Water Resistance           | kPa               | 12            | 14          | 18           | 20           | 24           |
| Water Inlet Pipe           | inch              | ZG3/4"        |             |              |              |              |
| Water Outlet Pipe          | inch              | ZG3/4"        |             |              |              |              |
| Max. Working Pressure      | MPa               | 1.6           |             |              |              |              |
| Condensing Water Pipe      | mm                | φ16           |             |              |              |              |
| Unit Net Dimension (W*D*H) | mm                | 692*130*657   | 892*130*657 | 1092*130*657 | 1292*130*657 | 1492*130*657 |
| Packing Dimension (W*D*H)  | mm                | 750*180*710   | 950*180*710 | 1150*180*710 | 1350*180*710 | 1550*180*710 |

**\*Condition:**

1. Cooling: Ambient temp. (DB/WB) 27/19 C, Water temp. (Inlet/Outlet): 7 C/12 C.
2. Heating\*: Ambient temp. (DB/WB) 21/- C, Water temp. (Inlet/):50 C.
3. Heating\*\*: Ambient temp. (DB/WB) 21/- C, Water temp. (Inlet/):70 C.

# Dimensions

Back

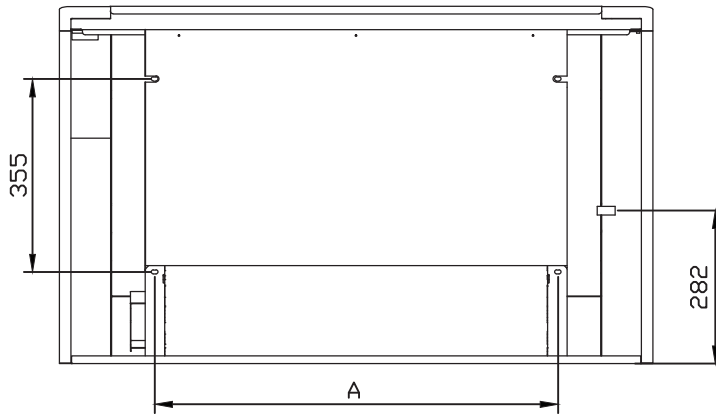

Front

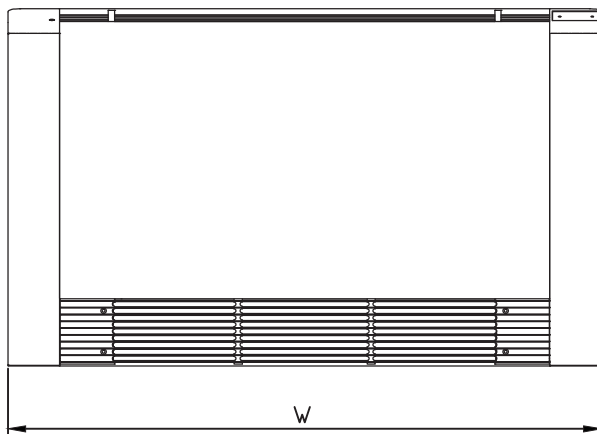

Side

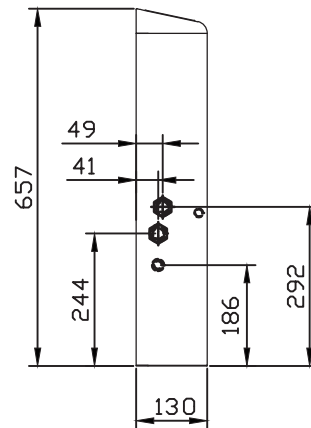

(\*Unit: mm)

| Model | FC-020VED | FC-032VED | FC-046VED | FC-058VED | FC-065VED |
|-------|-----------|-----------|-----------|-----------|-----------|
| W     | 692       | 892       | 1092      | 1292      | 1492      |
| A     | 342       | 542       | 742       | 942       | 1142      |

# Correction Factors

## Cooling Capacity Correction Factors

| EWT (°C)          | 5    | 6    | 7 | 8    | 9    | 10   | 11  | 12   |
|-------------------|------|------|---|------|------|------|-----|------|
| Correction Factor | 1.15 | 1.07 | 1 | 0.92 | 0.85 | 0.77 | 0.7 | 0.62 |

Note: air side condition, entering DB 27°C, WB 19.5°C.

## Heating Capacity Correction Factors

| EWT (°C)          | 35   | 40   | 45   | 50   | 55   | 60 | 65   | 70   |
|-------------------|------|------|------|------|------|----|------|------|
| Correction Factor | 0.36 | 0.49 | 0.62 | 0.74 | 0.87 | 1  | 1.13 | 1.26 |

Note: air side condition, entering DB 21°C.

## Cooling Capacity Correction Factors Based on Different Ambient Conditions

| WB (°C) | DB (°C) | 24   | 25   | 26   | 27 | 28   | 29   | 30   |
|---------|---------|------|------|------|----|------|------|------|
| 17      |         | 0.76 |      |      |    |      |      |      |
| 18      |         |      | 0.85 |      |    |      |      |      |
| 19      |         |      |      | 0.94 |    |      |      |      |
| 19.5    |         |      |      |      | 1  |      |      |      |
| 20      |         |      |      |      |    | 1.06 |      |      |
| 21      |         |      |      |      |    |      | 1.15 |      |
| 22      |         |      |      |      |    |      |      | 1.25 |

Note: entering cooling water temperature 7°C.

## Heating Capacity Correction Factors Based on Different Ambient Conditions

| DB (°C)           | 18  | 19   | 20   | 21 | 22   | 23   | 24  |
|-------------------|-----|------|------|----|------|------|-----|
| Correction Factor | 1.1 | 1.07 | 1.02 | 1  | 0.97 | 0.94 | 0.9 |

Note: entering heating water temperature 60°C.

# Wiring diagram

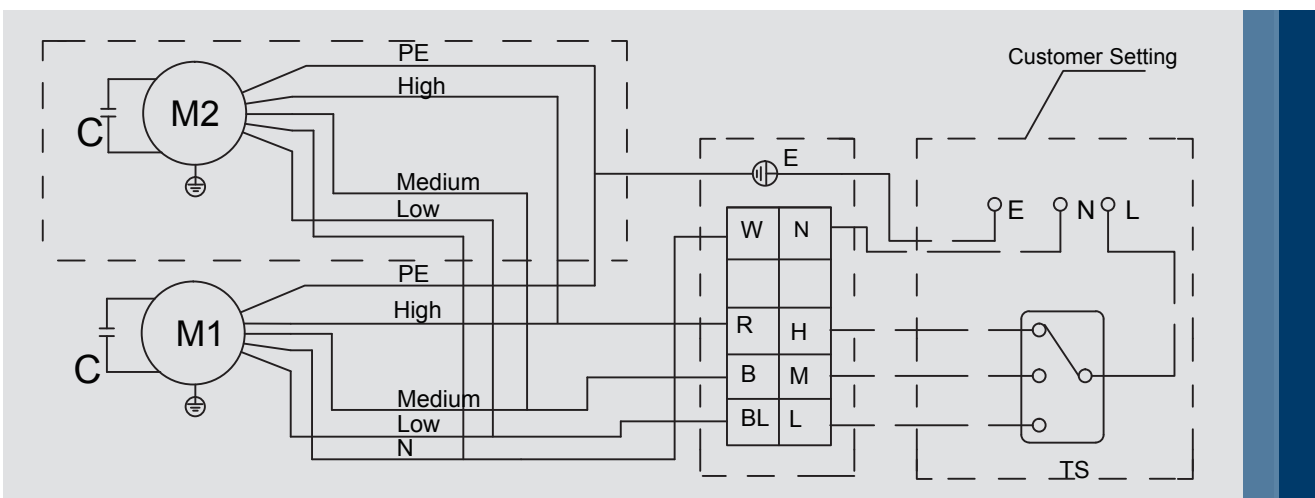

**B:**Black, **BL:**Blue, **R:**Red, **W:**White, **TS:** Fan Speed Controller, **C:**Capacitor, **M1/M2:**Four Speed Motor.  
**H:** High, **M:** Medium, **L:** Low, **E:** Earth Line, **L:** Live Line, **N:** Null Line

**\*Note:**

1. Wiring between speed terminals to speed controller
2. Components in dashed part may not exist in some models



We reserves the right to change any specification, design and information without any prior notice for further improvement on quality and performance.

